

## FilterBox 10A

Automatically cleaned for light to medium dust & fume applications. W3 tested.



The FilterBox 10A is equipped with a N24 fan for a maximum air flow capacity of 1 000 m<sup>3</sup>/h (600 CFM). An integrated silencer reduces noise from the fan and outlet air.

The unit has an advanced filter control system with automatic cleaning that starts when the air flow is too low. Depending on the model, it is equipped with mechanical cleaning for dust applications or a combination of mechanical and compressed air cleaning for fumes and dust.

FilterBox 10A is available either as a mobile unit on wheels or attached to a floor stand. Additional protection from harmful particles is provided if a HEPA filter is installed.

For dust applications, the unit is cleaned mechanically. For welding fumes it uses a combination of mechanical and compressed air cleaning.









For welding applications, compressed air cleaning is required.

- User friendly and superior filter cleaning, mechanical and/or with compressed air for long filter life
- Automatic damper preventing dust from leaking out while cleaning
- Dust free filter replacement and emptying of dust bin
- Third party approval for welding fumes category W3 according to EN 15012-2









<b>Product name</b>	FilterBox 10A
<b>Noise level (dB(A))</b>	66
<b>Filter efficiency (%)</b>	99
<b>Compressed air requirement</b>	DIN ISO 8573-1, class 5/5/4 (7 bar)
<b>Installation</b>	Indoor
<b>Material</b>	Casing in rotomoulded plastic
<b>Dustbin volume (l)</b>	15
<b>Extraction arm diameter (mm)</b>	160
<b>Airflow (m<sup>3</sup>/h)</b>	1000
<b>Filter Area (m<sup>2</sup>)</b>	13
<b>Filter type</b>	Cartridge
<b>Number of filter elements</b>	1
<b>Filter material</b>	Polyester PW13
<b>Electric plug</b>	Without



## FilterBox 10A

Image	Description	Power Voltage (V)	Power (kW)	No of phases	Frequency (Hz)	Arm length (m)	Mounting	Weight (kg)	Filter cleaning method	Model
	FilterBox 10 A.	230	0.9	3	50	3	Mobile	102	Mechanical	12653663*
	FilterBox 10 A.	230	0.9	3	50	3	Floor mounted	99	Mechanical	12653763*
	FilterBox 10 A.	400	0.9	3	50	3	Mobile	102	Mechanical	12653863*
	FilterBox 10 A.	400	0.9	3	50	3	Floor mounted	99	Mechanical	12653963*
	FilterBox 10 A	200	0.9	3	50	3	Mobile	102	Mechanical ,Compressed air	12679163
	FilterBox 10 A	200	0.9	3	50	3	Floor mounted	99	Mechanical ,Compressed air	12679263
	FilterBox 10 A.	200	0.9	3	60	3	Floor mounted	99	Mechanical	12657563*
	FilterBox 10 A.	120	0.75	1	60	3	Mobile	102	Mechanical	12657663*
	FilterBox 10 A.	230	0.9	3	60	3	Mobile	102	Mechanical	12656863*
	FilterBox 10 A.	230	0.9	3	60	3	Floor mounted	99	Mechanical	12656963*
	FilterBox 10 A.	460	0.9	3	60	3	Mobile	102	Mechanical	12657063*
	FilterBox 10 A.	460	0.9	3	60	3	Floor mounted	99	Mechanical	12657163*
	FilterBox 10 A.	575	0.9	3	60	3	Mobile	102	Mechanical	12657263*
	FilterBox 10 A.	575	0.9	3	60	3	Floor mounted	99	Mechanical	12657363*
	FilterBox 10 A.	200	0.9	3	60	3	Mobile	102	Mechanical	12657463*

## FilterBox 10A

Image	Description	Power Voltage (V)	Power (kW)	No of phases	Frequency (Hz)	Arm length (m)	Mounting	Weight (kg)	Filter cleaning method	Model
	FilterBox 10 A	230	0.9	3	50	3	Mobile	102	Mechanical ,Compressed air	12655263
	FilterBox 10 A	230	0.9	3	50	3	Floor mounted	99	Mechanical ,Compressed air	12655363
	FilterBox 10 A	400	0.9	3	50	3	Mobile	102	Mechanical ,Compressed air	12655463
	FilterBox 10 A	400	0.9	3	50	3	Floor mounted	99	Mechanical ,Compressed air	12655563
	FilterBox 10 A	230	0.75	1	50	3	Mobile	102	Mechanical ,Compressed air	12655663
	FilterBox 10 A	230	0.75	1	50	3	Floor mounted	99	Mechanical ,Compressed air	12655763
	FilterBox 10 A	110	0.75	1	50	3	Mobile	102	Mechanical ,Compressed air	12655863
	FilterBox 10 A	230	0.75	1	50	3	Floor mounted	99	Mechanical ,Compressed air	12655963
	FilterBox 10 A.	120	0.75	1	60	3	Floor mounted	99	Mechanical	12657763*
	FilterBox 10 A	575	0.9	3	60	3	Floor mounted	99	Mechanical ,Compressed air	12658363
	FilterBox 10 A.	230	0.75	1	50	3	Mobile	102	Mechanical	12654063*
	FilterBox 10 A.	230	0.75	1	50	3	Floor mounted	99	Mechanical	12654163*
	FilterBox 10 A.	110	0.75	1	50	3	Mobile	102	Mechanical	12654263*
	FilterBox 10 A.	110	0.75	1	50	3	Floor mounted	99	Mechanical	12654363*
	FilterBox 10 A.	230	0.75	1	60	3	Mobile	102	Mechanical	12681563*

# FilterBox 10A











Image	Description	Power Voltage (V)	Power (kW)	No of phases	Frequency (Hz)	Arm length (m)	Mounting	Weight (kg)	Filter cleaning method	Model
	FilterBox 10 A.	230	0.75	1	60	3	Floor mounted	99	Mechanical	12681663*
	FilterBox 10 A	230	0.9	3	60	3	Mobile	102	Mechanical ,Compressed air	12657863
	FilterBox 10 A	230	0.9	3	60	3	Floor mounted	99	Mechanical ,Compressed air	12657963
	FilterBox 10 A	460	0.9	3	60	3	Mobile	102	Mechanical ,Compressed air	12658063
	FilterBox 10 A	460	0.9	3	60	3	Floor mounted	99	Mechanical ,Compressed air	12658163
	FilterBox 10 A	575	0.9	3	60	3	Mobile	102	Mechanical ,Compressed air	12658263
	FilterBox 10 A	200	0.9	3	60	3	Mobile	102	Mechanical ,Compressed air	12658463
	FilterBox 10 A	200	0.9	3	60	3	Floor mounted	99	Mechanical ,Compressed air	12658563
	FilterBox 10 A	230	0.75	1	60	3	Mobile	102	Mechanical ,Compressed air	12681763
	FilterBox 10 A	230	0.75	1	60	3	Floor mounted	99	Mechanical ,Compressed air	12681863
	FilterBox 10 A	120	0.75	1	60	3	Mobile	102	Mechanical ,Compressed air	12658663
	FilterBox 10 A.	400	0.9	3	50	Without	Floor mounted	99	Mechanical	12686263*
	FilterBox 10 A	120	0.75	1	60	3	Floor mounted	99	Mechanical ,Compressed air	12658763
	FilterBox 10 A	400	0.9	3	50	Without	Floor mounted	99	Mechanical ,Compressed air	12685063
	FilterBox 10 A	400	0.9	3	50	Without	Mobile	102	Mechanical ,Compressed air	12686763

## FilterBox 10A

Image	Description	Power Voltage (V)	Power (kW)	No of phases	Frequency (Hz)	Arm length (m)	Mounting	Weight (kg)	Filter cleaning method	Model
	FilterBox 10 A	380	0.75	3	60	3	Mobile	102	Mechanical ,Compressed air	12689263
	FilterBox 10 A.	400	0.9	3	50	Without	Mobile	102	Mechanical	12686863*
	FilterBox H 10A	400	0.9	3	50	Without	Mobile	102	Mechanical ,Compressed air	12687463

\*Mechanical filter cleaning only

## FilterBox 10A

	Accessory	Part No
	Outlet with duct connection D=200mm	12376749
	Spotlight original, 24V, 20W	12376616*
	Spark protection for Original hood	10551335
	LED light/fan switch Original	10376922
	Filter-PW-FB-13	12332672
	Filter-PW HE-FB-15	12371106
	Filter PWA-FB-15	12371412
	HEPA filter H13 10m2 Filterbox	12376615
	Bags for Filterbox dust bin, 10pcs	12376618
	HEPA filter H14 10m2 Filterbox	12376756
	Sensor clamp to be attached to the earth cable of the welding power source.	14372199

\*Switch for light (no fan start)

## FilterBox 10A

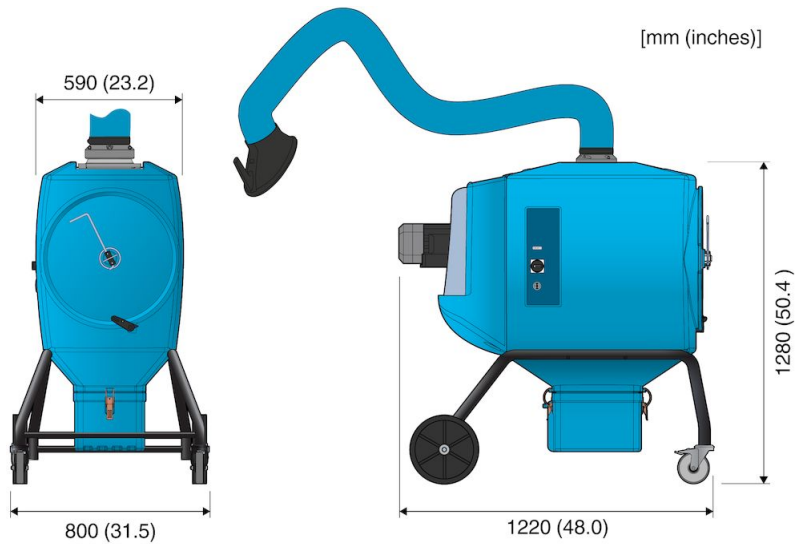

FilterBox 10A mobile

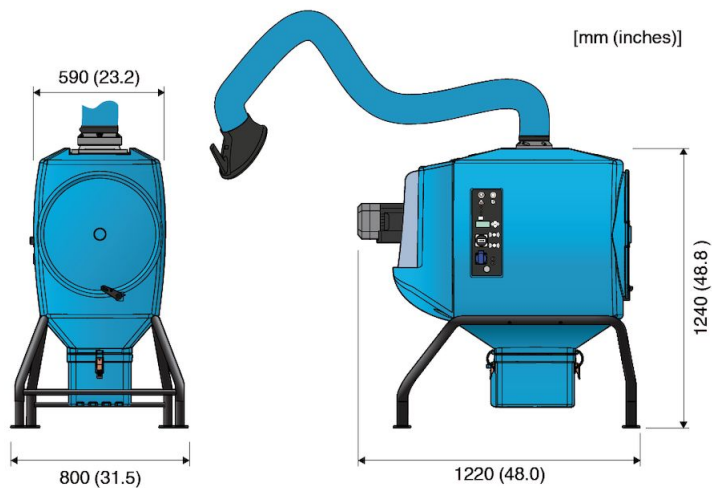

Floor mounted FilterBox 10A

FilterBox 10A Floor